



# WP-1

## WEATHERPROOF ENCLOSURE FOR RW & SM SERIES DUCT SMOKE DETECTORS

### PRODUCT SPECIFICATIONS

USE:	RW & SM-Series duct smoke detectors
CONDUIT KNOCKOUTS:	On bottom: 3 convertible 0.75" to 1.75"
METAL WORK:	16ga CRS with white painted finish
FRONT ACCESS:	Removable cover, secured with two screws
HARDWARE:	Enclosure mounting screws included
PROTECTION RATING:	3R – UL 50, NEMA, and CSA Outdoor: Internal equipment protected from falling rain, etc.; undamaged by ice formation
ENVIRONMENTAL:	See RW & SM Series duct smoke detector specifications
APPROVALS:	UL: NITW.E69392 CUL: NITW7.E69392

**! CAUTION:** DE-ENERGIZE ALL POWER BEFORE INSTALLATION OR SERVICE

### MOUNTING

1. Remove paper backing from mounting template (RW / SM kit) and affix to the air duct at desired location.
2. Using the template as a guide, drill or punch (2) 1-1/4" dia. holes in the air duct, for the sampling tube / exhaust tube.
3. Position the WP-1 enclosure in such a way that the holes (on the template and WP-1) are lined up with each other.
4. Secure the WP-1 enclosure to the air duct with (4) #12 x 3/4" sheet metal screws (WP-1 kit).
5. Connect sampling tube / exhaust tube to the RW / SM duct detector (position the sampling tube in such a way that air flows into the intake holes).
6. Fit the RW / SM duct smoke detector into the 1-1/4" holes on the air duct.
7. Secure the duct smoke detector with (4) #12 x 3/4" sheet metal screws (RW / SM kit) to the WP-1 enclosure.

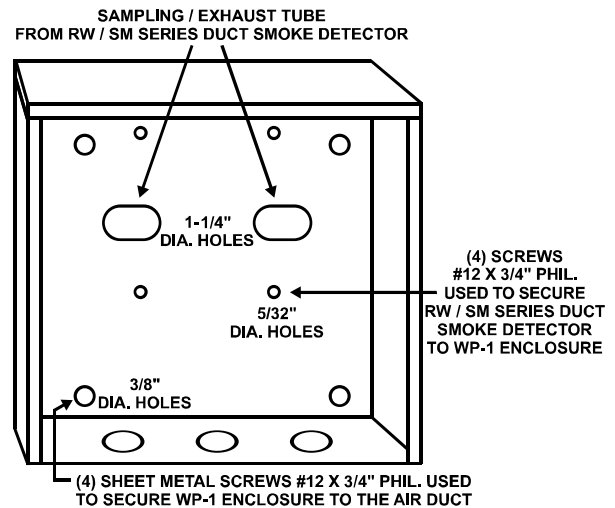

**FOR ADDITIONAL APPLICATION INFORMATION AND/OR ASSISTANCE,  
PLEASE CONTACT OUR TECHNICAL SUPPORT HOTLINE. (888) 332-2241**

